



Ficha Técnica
/Data Sheet



Proyector
/Projector

TURIA
200W

ILUMINIA

Información general / General information

Producto / Product:	Proyector AC DIRECT TURIA
Familia / Family:	Proyectores
Marcado CE / CE marking:	Si
Certificado ROHS / ROHS Certificate:	Si
Garantía / Warranty:	3 años
Uso / Aplicación / Use / Application:	Uso comercial, industrial, en exteriores.

Referencias / References

Referencia / Reference:	LY506	LY366	LY367
Potencia / Power:	200W	200W	200W
CCT (K) / CCT (K):	3000 K	4000 K	6000 K
Flujo lum. nominal (lm) / Nominal luminous flux (lm):	25200 lm	25200 lm	25200 lm
Flujo luminoso (lm) / Luminous flux (lm):	23550 lm	24000 lm	24000 lm

Información técnica / Technical information

LED / LED:	SMD2835
Driver / Driver:	-
Regulable / Dimmable:	-
Regulación opcional / Optional regulation:	-
Tensión AC / Voltage AC (V):	100-265 V
Tensión DC / Voltage DC (V):	-
Frecuencia (Hz) / Frequency (Hz):	50/60Hz
Factor de desplazamiento (DF) / Displacement Factor (DF):	≥0,90
Protector de sobretensiones / Surge protector:	8 kV
Ángulo apertura / Beam Angle:	110°
Ángulo apertura opcional / Optional Beam Angle:	-
Vida útil (h) / Life Span (h):	30.000 h
CRI (Ra) / CRI (Ra):	≥80 Ra
Grado de estanqueidad (IP) / Degree of Tightness (IP):	IP66
Grado de protección impacto mecánico (IK) / Mechanical Protection Level (IK):	IK07
Rango temperatura de trabajo / Working temperature range (C°):	-20°+50°

Información mecánica / Mechanical information

Forma / Shape:	Rectangular
Conexión / Connection:	L+N+TT
Dimensiones cable alimentación / Power cable dimensions:	-
Dimensiones cable regulación / Regulation cable dimensions:	-
Clase de protección eléctrica / Protection class:	CLASE I
Material de la carcasa / Housing Material:	Fundición de aluminio
Color de la carcasa / Housing Color:	Negro
Material del reflector / Reflector Material:	NANOGRADO
Color del reflector / Reflector Color:	Blanco
Material del Protector / Protector Material:	Cristal templado
Modo de instalación / Installation Mode:	Mediante lira
Longitud total (L) / Total length (L):	285 mm
Anchura total (W) / Total width (W):	33 mm
Altura total (H) / Total Height (H):	309 mm
Peso Neto (Kg) / Net Weight (Kg):	2,40 Kg

Información package / Package information

Unidades Inner Box / Inner Box Units:	1 ud
Peso Inner Box / Inner Box Weight (Kg):	2,57 Kg
Unidades Master Carton / Master Carton Units:	5 ud
Peso Master Carton / Master Carton Weight (Kg):	13,45 Kg

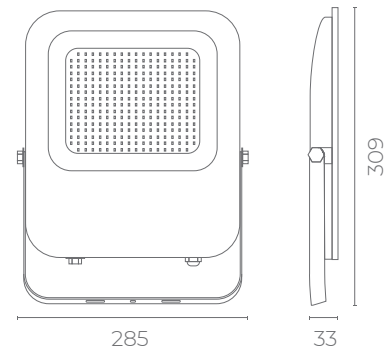
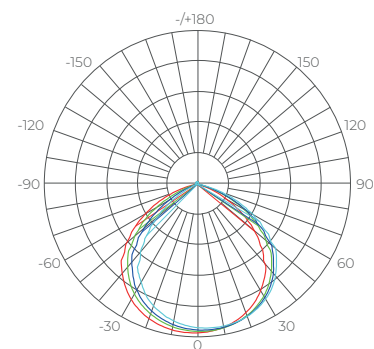
Imágenes / Images**Dibujo técnico** / Technical drawing**Datos fotométricos** / Photometric data**Información adicional** / Additional Information

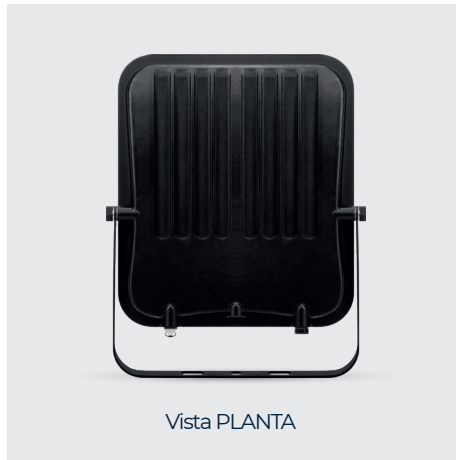
Imágenes / Images**Accesorios / Accessories**

- CN761** Conector estanco IP68 / 3x0,5-2,5mm² 16A 450VA
- CN118** Conector estanco IP68 Tipo T / 3x0,5-2,5mm² 16A 450VA
- CN328** Conector estanco IP68 Tipo T / 3x0,5-2,5mm² 16A 450VA